

EWOS16-UW

Ultra Low Power micro-OCXO for Underwater Systems

PRODUCT OVERVIEW

EWOS16-UW is a customized micro-OCXO for underwater systems with a record low power consumption at 50 mW at 25°C to optimize the mission time and downsize the battery. Powered with 5V, it delivers an ultra-stable frequency of 16.384 MHz with a record low thermal sensitivity ± 50 ppb (typ). EWOS16-UW can be disciplined thanks to its tuning pin and is highly resistant to shocks and vibrations.



KEY FEATURES

- 5V supply and 16,384 MHz clipped sine output
- ± 50 ppb (typ.) thermal sensitivity
- 50 mW @ 25°C (typ.)
- ± 2 ppb/day after 30 days (typ.)

DIMENSIONS & PIN-OUT

BOTTOM VIEW

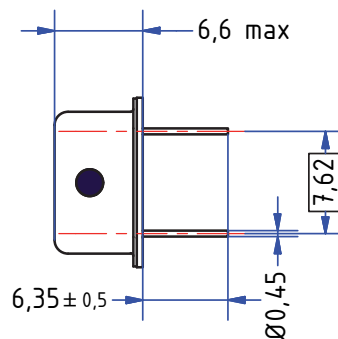
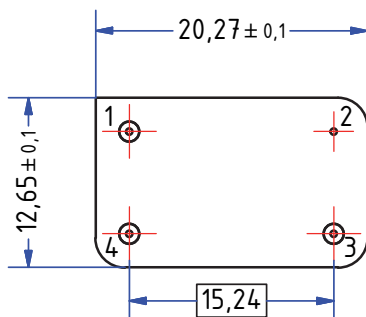

PIN NUMBER	FUNCTION
1	Frequency control
2	Ground
3	RF Out
4	Power Supply

ORDERING INFORMATION

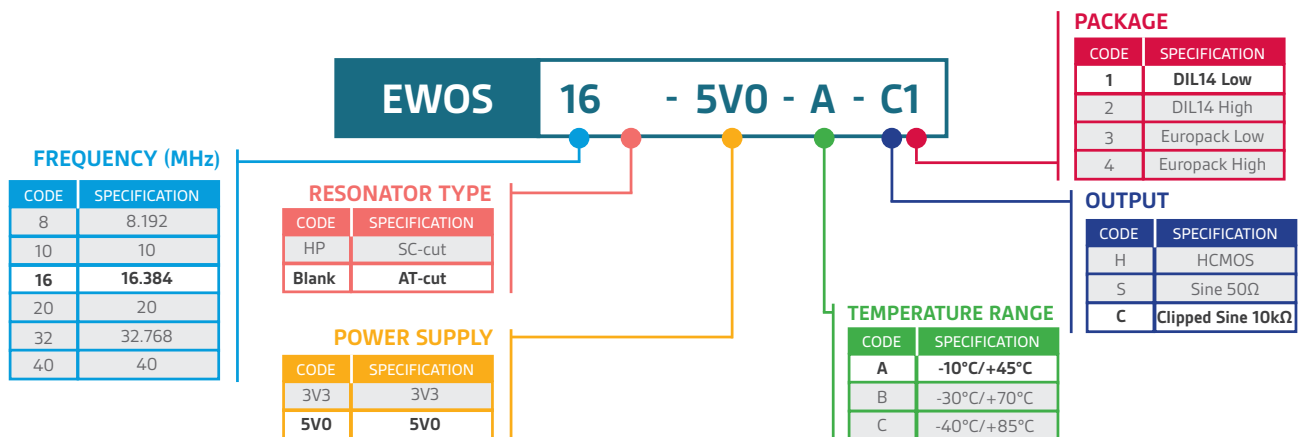

ELECTRICAL CHARACTERISTICS

PARAMETERS	Unit	Min	Typ.	Max	Note	Comments
Output Frequency	MHz		16.384		1	
Temperature Range						
• Operating	°C	-10		+45		Ordering Code A / Stay functional at + 50°C but stability may not be met
• Storage	°C	-55		+95		
Supply Voltage	V		5			±5%
Supply Current						
• Warm-up	mA			220	3	During 10s max @25°C / 20s max @5°C
• Steady state / -10°C	mA		20	25	1	
• Steady state / +5°C	mA		15	18	1	
• Steady state / +25°C	mA		10	13	1	
• Steady state / +45°C	mA		4	6	1	
Frequency Stability						
• Initial frequency accuracy	ppm		±1	±2	1	+25°C, Vctrl = 1.1 V
• Vs operating temperature range	ppb		±50	±90	1	
• Vs supply voltage variation	ppm		±0.1	±0.2	3	5V ± 5%
• Vs load	ppm		±0.1	±0.2	3	(10 KΩ//10 pF) ± 10%
• Short-term	(τ=0.1s)	10 ⁻¹⁰	1	3	3	Allan deviation @ 16.384 MHz
	(τ=1s)	10 ⁻¹⁰	4	10	3	
• Aging						
	Per day	ppb	±2	±5	3	After 30 days
	First year	ppm		±1.5	3	
	After 20 years	ppm		±5	3	
• Acceleration sensitivity	ppb/G		±1		3	Worst direction
• Warm-Up Time	sec			10	3	To ±1 ppm of final frequency (1 hour)
	sec			60	3	To ±100 ppb of final frequency (1 hour)
Phase Noise @ 16.384 MHz						
• 10 Hz	dBc/Hz		-105		2	
• 100 Hz	dBc/Hz		-135		2	
• 1 KHz	dBc/Hz		-145		2	
• 10 KHz	dBc/Hz		-148		2	
Clipped sinewave output parameters						
• Output Level	Vpp	0.8	1.2	1.5	3	Clipped sinewave - DC cut - Load 10kΩ//10 pF
• Output Impedance	kΩ		1		3	
	pF		5		3	
Frequency Tuning						
• Tuning Voltage	V	0		3.0	3	Referred to nominal frequency measured at 25°C. Apply control voltage between 0V to 3V or use pull-down resistor between Vtune and ground. If Vtune not connected then OCXO frequency will be at max value. If R=0ohm is used, the OCXO frequency will be at minimum value.
• Tuning Range	ppm	±4	±5		2	
• Tuning Input Impedance	kΩ		10		3	
	pF		100		3	
Weight	grams		4			

Notes

1. Parameter inspected at 100% | 2. Parameter inspected by sampling | 3. Parameter guaranteed by design and characterization

ENVIRONMENTAL CONDITIONS

Shocks	1500G peak / 0.5 ms / 3 axis ; MIL-STD-883 method 2002, Test Condition B
Vibrations	16.91 Grms / 10 to 2000 Hz Random / 3 min per axis, MIL STD 202-214 cond E
Soldering instructions	Hand soldering with recommended pins temperature: 235°C ±5°C, t=10s ±05s (260°C max for 5s max) Selective wave soldering with limitation of pre-heating to reach the max temperature of 85°C (body of component) and 3 s max at max temperature Use of no-clean solder paste When connecting a pad to a copper plane, thermal pads are recommended
Mounting instructions	Metallic Case glued onto the PCB, without glue overflow into the metallized holes No spacer material between OCXO and PCB
PCB cleaning/washing	Washable with a temperature below 85°C

OCXO HERMETICITY

	Metallic housing hermetically sealed
	Fine Leaks and Gross Leaks tests performed 100%

EWOS16-UW V1.1 | Updated on 29th October 2021 | This document is the property of Syrlinks. Information contained is not contractual. It is susceptible to modifications without advance notice.